

質量 2056g
T管 4T175 ABCF

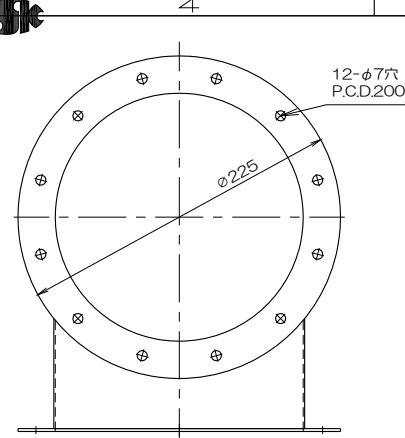

質量 1552g
フランジ付T管4T 175B(C)F

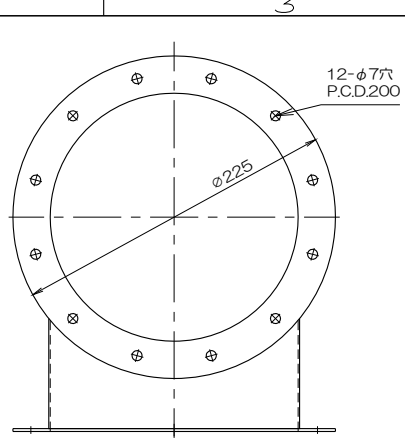
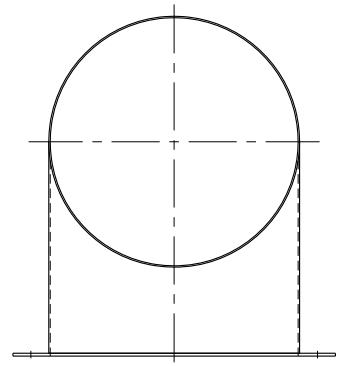
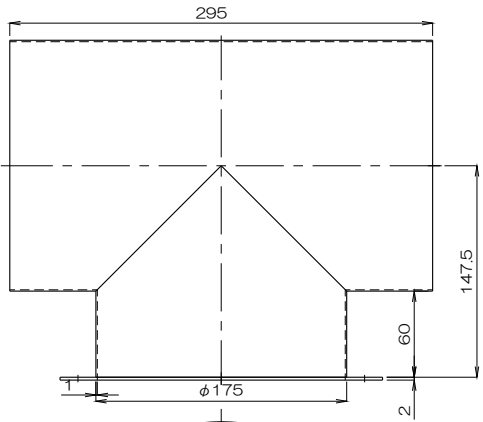
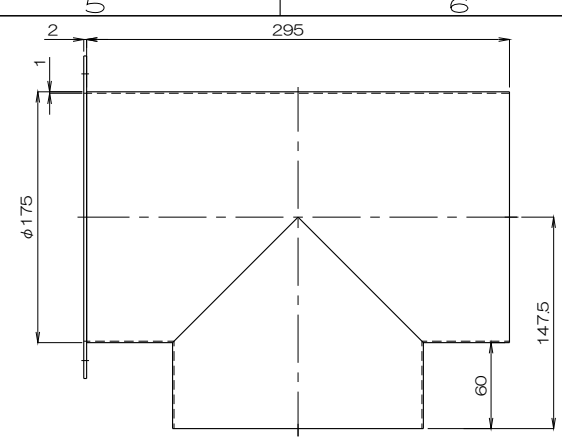

質量 1552g
T管 4T175 AF

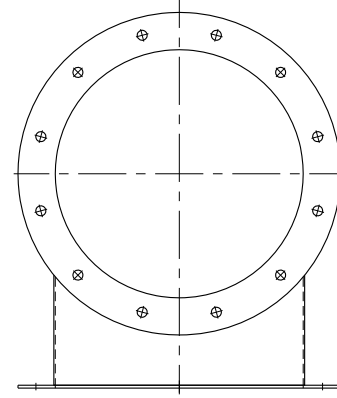

質量 1805g
フランジ付T管4T 175 AB(C)F

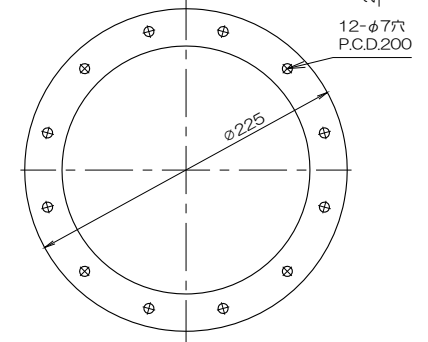
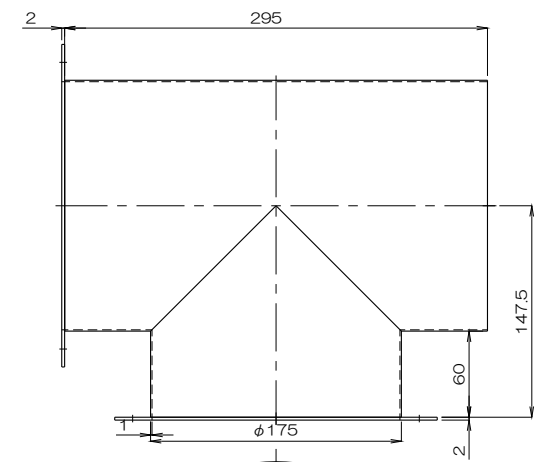

No.	修正内容	場所	日付	数	担当	製図	設計	尺度	図番	配布先	営業 資材購買 総合組立 金属加工	株式会社 関西電熱 Kansai Electric Heat Corp.	仕向	図面名称
								1:F	230517MN-09					
								File name						